

Build it with Bosch!

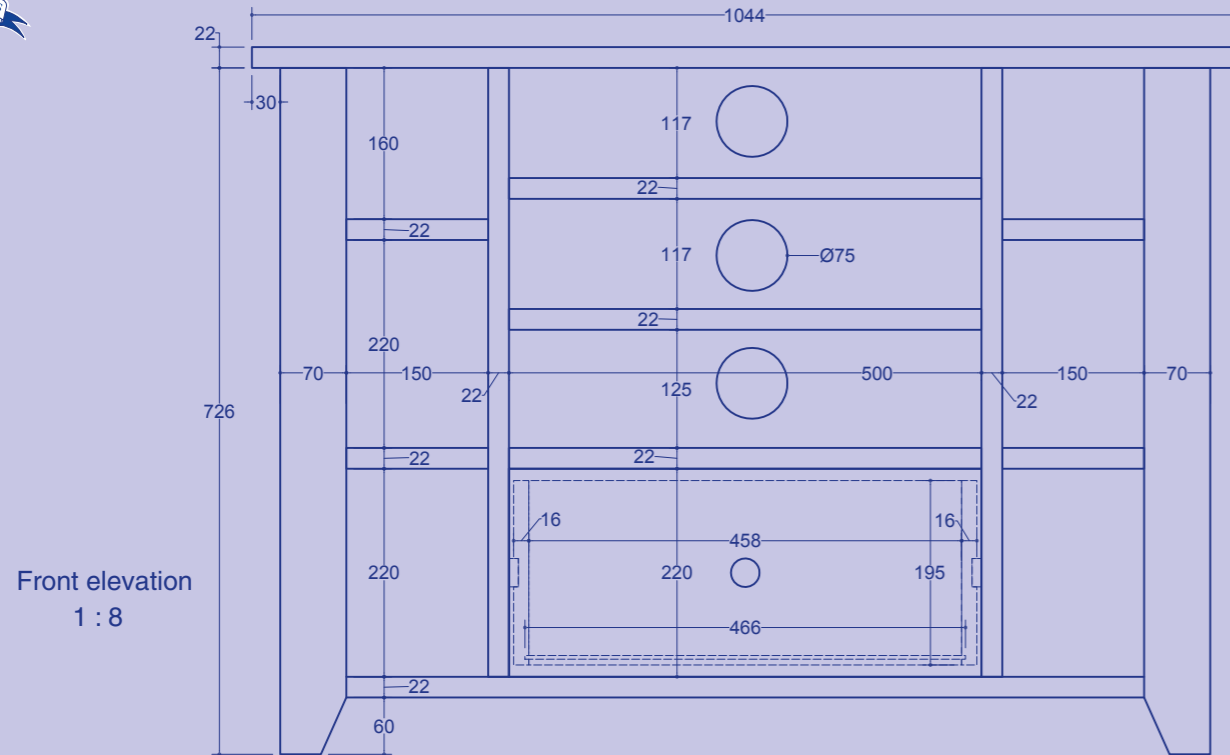

Front elevation
1 : 8

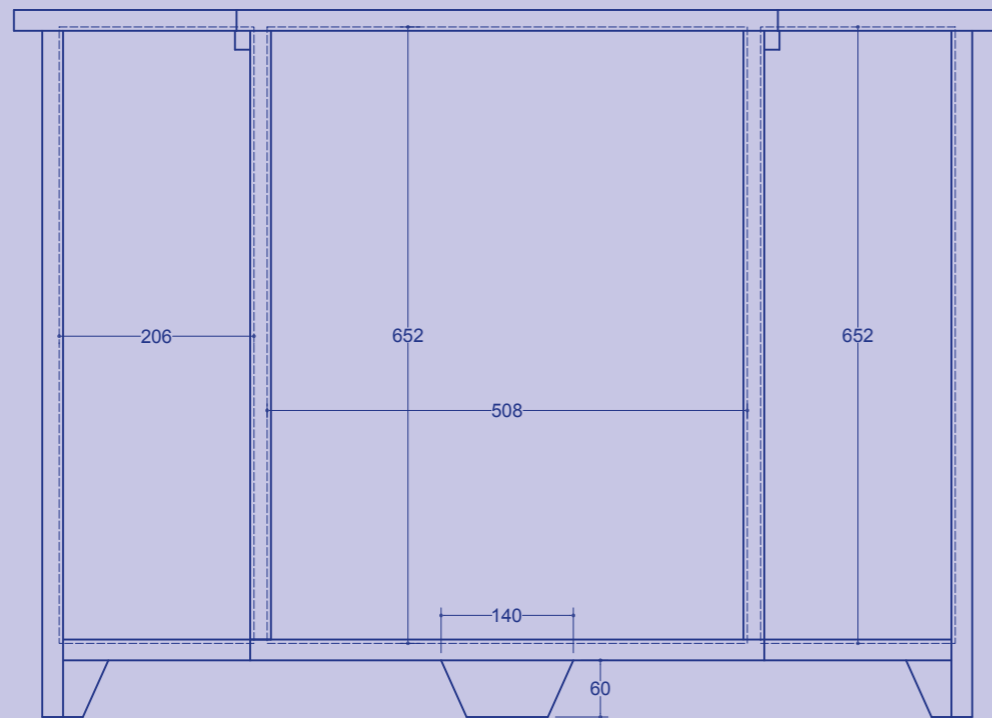

Rear elevation
1 : 8

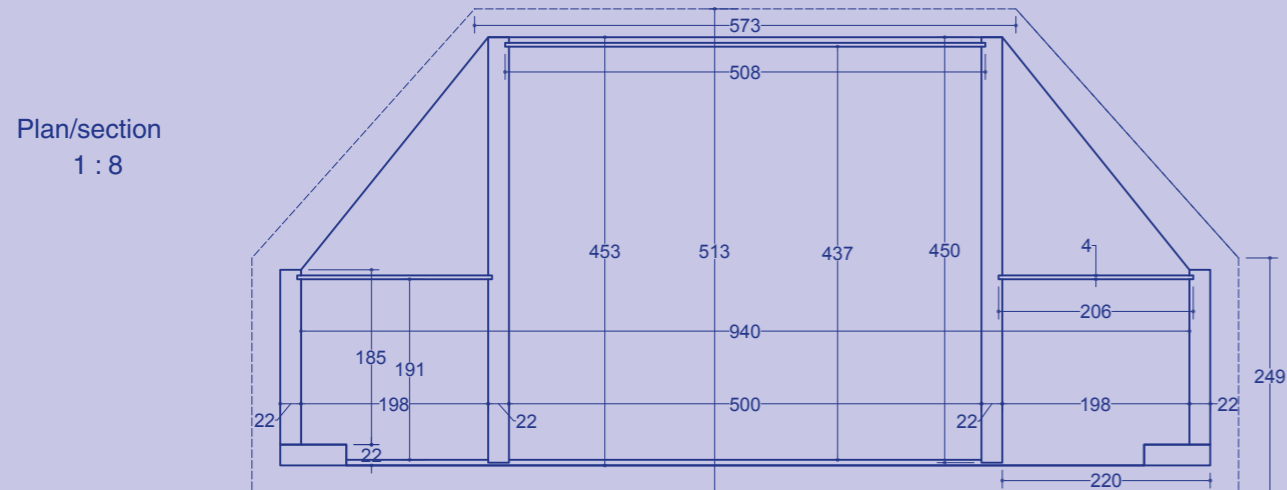

Plan/section
1 : 8

Cutting List			
TOP	1 @ 1044 x 513 x 22	BACK FOOT	1 @ 140 x 60 x 22
SIDES	2 @ 726 x 185 x 22	MIDDLE SHELVES	3 @ 500 x 437 x 22
BOTTOM	1 @ 940 x 453 x 22	OUTER SHELVES	4 @ 198 x 191 x 22
FRONT LEGS	2 @ 726 x 70 x 22	DRAWER FRONT	1 @ 500 x 220 x 18
DIVIDERS	2 @ 644 x 450 x 22	BOX SIDES	2 @ 409 x 195 x 16
MAIN BACK	1 @ 652 x 508 x 4	BOX ENDS	2 @ 458 x 195 x 16
OUTER BACKS	2 @ 652 x 206 x 4	DRAWER BOTTOM	1 @ 466 x 385 x 4

TOOLS YOU
WILL NEED



GKT 55 GCE Professional
Plunge Saw



GEX 125-150 AVE
Professional
Random Orbit Sander



GFF 22 A Professional
Biscuit Joiner



GKF 600
Professional 1/4in
Palm Router

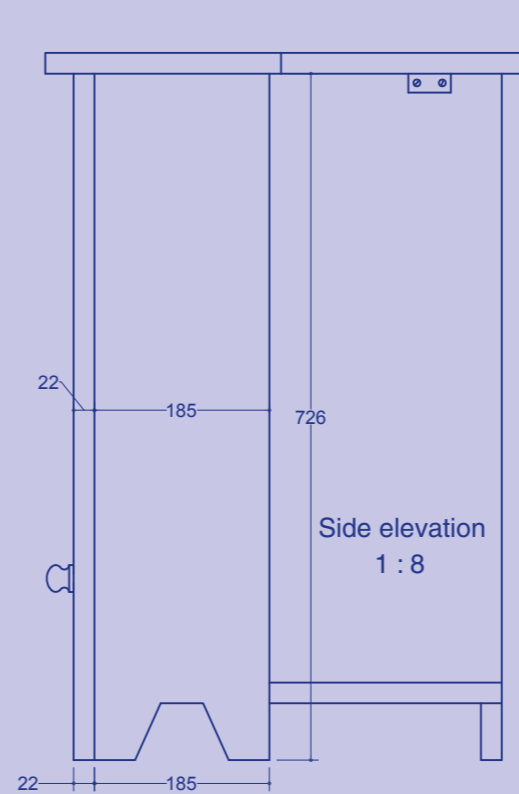

Side elevation
1 : 8

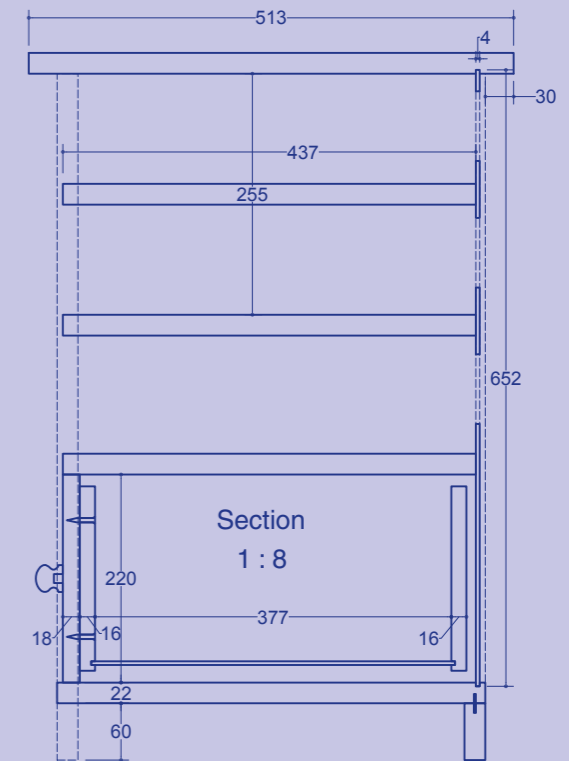

Section
1 : 8

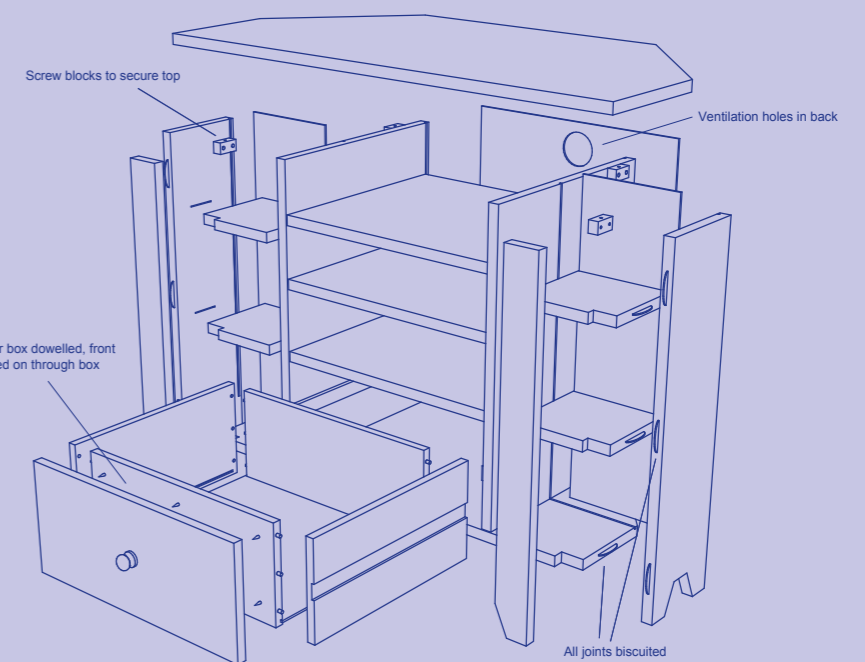

Design Copyright – Alan Holtham

Items made using LineMine plans are for personal use. Designs may not be reproduced for commercial purposes without the prior consent of the copyright owner.

Guild of Master Craftsman Publications Ltd 2011

No part of this design may be reproduced, stored in a retrieval system or transmitted in any form or by any means without the prior permission of the publisher and copyright owner. The author and publisher can accept no legal responsibility for any consequences arising from the application of information, advice or instructions given on the design.

GMC Publications Ltd www.thegmcgroup.com